

No. 644,972.

Patented Mar. 6, 1900.

R. A. FESSENDEN.
INDUCTION COIL FOR X-RAY APPARATUS.

(Application filed Mar. 19, 1897.)

(No Model.)

2 Sheets—Sheet 1.

Fig. 1.

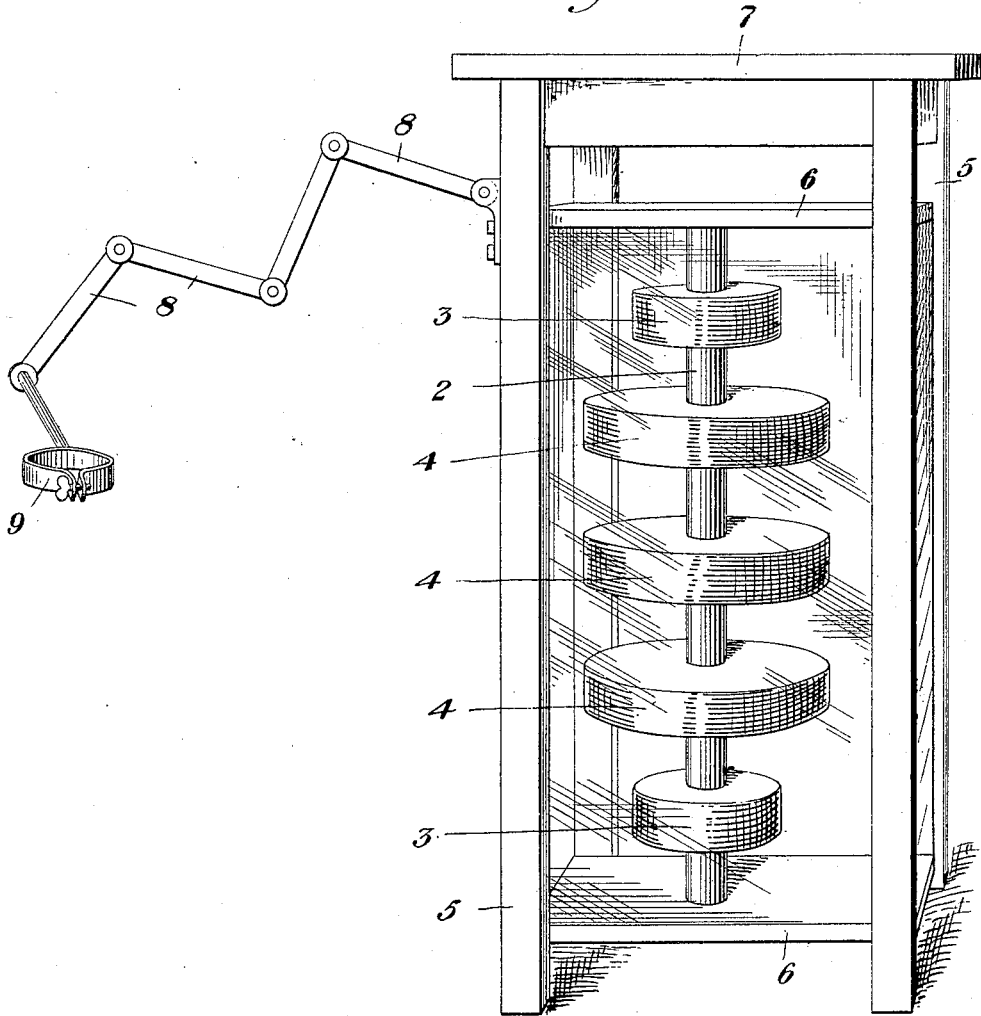

Witnesses:
Peter Edwards
Watson Lacy

Inventor:
Reginald A. Fessenden
G. M. Clarke
his attorney

No. 644,972.

Patented Mar. 6, 1900.

R. A. FESSENDEN.
INDUCTION COIL FOR X-RAY APPARATUS.

(Application filed Mar. 19, 1897.)

(No Model.)

2 Sheets—Sheet 2.

Fig. 2.

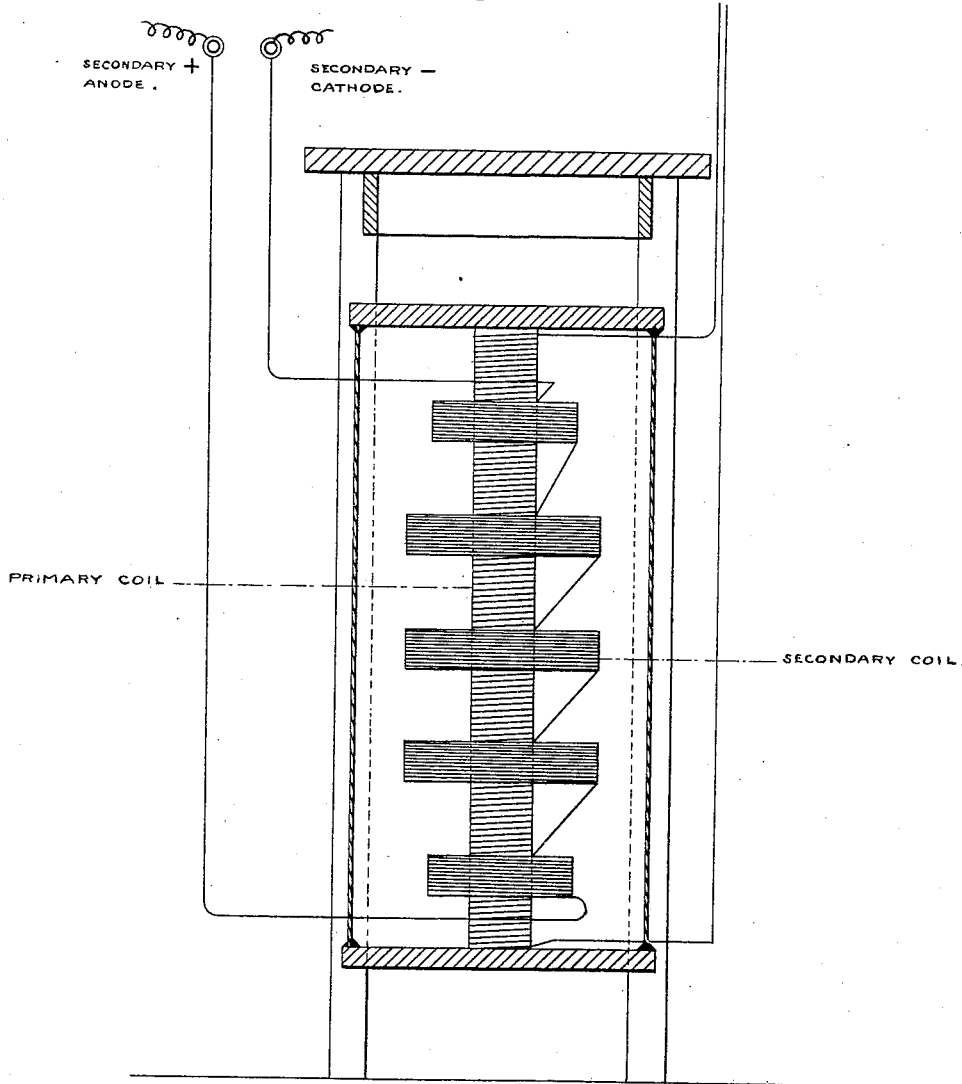

WITNESSES

D. Edwards.
Watson Large.

INVENTOR

Roginald A. Fessenden
By C. M. Clarke
his Attorney

UNITED STATES PATENT OFFICE.

REGINALD A. FESSENDEN, OF ALLEGHENY, PENNSYLVANIA, ASSIGNOR TO
THE FESSENDEN MANUFACTURING COMPANY, OF PITTSBURG, PENN-
SYLVANIA.

INDUCTION-COIL FOR X-RAY APPARATUS.

SPECIFICATION forming part of Letters Patent No. 644,972, dated March 6, 1900.

Application filed March 19, 1897. Serial No. 628,375. (No model.)

To all whom it may concern:

Be it known that I, REGINALD A. FESSENDEN, a citizen of the United States, residing at Allegheny, in the county of Allegheny and State of Pennsylvania, have invented or discovered a new and useful Improvement in Induction-Coils for X-Ray Apparatus, of which the following is a full, clear, and exact description.

My invention consists of an improvement in apparatus employed in the production of X-rays, and relates particularly to the construction of the induction-coil and the method of winding and insulating it and to the stand employed to contain the coil with its fixtures.

In the use of such apparatus in order to obtain the best results and effects it is necessary that there be as large a number as possible of electrical discharges from the induction-coil, and this is only secured, I have found, when the ratio of the length of the core of the induction-coil is to its diameter at least as thirty to one, as I have found that with this ratio the time constant of the coil may be much reduced, allowing the coil to be magnetized more quickly. Ordinarily this ratio is about ten to one, owing to the practical difficulties of making and mounting in the usual horizontal manner coils of such a high ratio, due to the danger of cracking the insulation by the sheer weight of the coil when of such great proportionate length.

Figure 1 is a perspective view of the exterior of my improved stand and contained induction-coil. Fig. 2 is a vertical sectional view showing the primary and secondary coils mounted in the supporting-framework, the terminal connections being indicated in diagram.

Referring to the drawings, which illustrate my improvement in perspective, 2 is the core, of iron wire, provided with the usual primary and secondary coils 3 4.

In order to enable vertically-mounted coils to give the proper efficiency in a convenient

manner, I have found it necessary to mount the whole coil inside of an insulating-framework 5, which may or may not be entirely closed, thereby effectually protecting the coil from mechanical injury and providing perfect insulation by the supporting-plates 6 6, made of insulating material, the whole construction occupying but a limited floor-space. By this method of mounting also the coils of the secondary are prevented from resting against any other substance than the insulation of the core of the coil, which would be necessary to prevent bending if the core was mounted horizontally, and great mechanical strength is also given to the core, whereby it may be readily transported for long distances. When supported in this manner, the insulating-framework may, if desired, constitute an upright table provided with a top 7, and to one of the upright members of the framework is secured a jointed arm 8, to the end of which is adjustably secured a tube-holder 9, whereby the tube may be suspended at any desired location in relation to the core.

If desired, the sides of the framework may be inclosed in glass or other suitable insulating material and the inclosed space surrounding the coil filled with an insulating fluid, such as oil.

Having described my invention, what I claim, and desire to secure by Letters Patent, is—

An induction-coil vertically mounted in an insulating-framework surrounding said coil, adapted to support it at more than one point, provided with a table-top and a movable arm attached to the insulating-framework provided with a tube-holder, substantially as and for the purposes set forth.

In testimony whereof I have hereunto set my hand this 27th day of January, 1897.

REGINALD A. FESSENDEN.

Witnesses:

PETER J. EDWARDS,
C. M. CLARKE.